

PULL MASTER MODEL H 10 SPECIFICATIONS

STANDARD DRUM DIMENSIONS

| | | |
|-------------------------|-----------------|--------------------|
| Model H10-3-50-1 | Barrel Diameter | 7 1/2" (190 mm) |
| | Flange Diameter | 14 5/8" (371.5 mm) |
| | Barrel Length | 10" (254 mm) |
| Model H10-3-50-2 | Barrel Diameter | 9 1/2" (241.3 mm) |
| | Flange Diameter | 14 5/8" (371.5 mm) |
| | Barrel Length | 10" (254 mm) |

CABLE STORAGE CAPACITY

| Size of Wire Rope | Model H10-3-50-1 | Model H10-3-50-2 |
|-------------------|------------------|------------------|
| 1/4" | 1250 ft (381 m) | 950 ft (290 m) |
| 5/16" | 850 ft (259 m) | 655 ft (200 m) |
| 3/8" | 550 ft (168 m) | 433 ft (132 m) |
| 7/16" | 452 ft (138 m) | 328 ft (100 m) |
| 1/2" | 360 ft (110 m) | 242 ft (72 m) |
| 9/16" | 280 ft (85 m) | 223 ft (68 m) |
| 5/8" | 218 ft (66 m) | 160 ft (49 m) |

For larger cable storage capacities, consult the factory.

MAXIMUM LINE PULL (at Max. Pressure)

| | |
|-------------------------|--------------------|
| Model H10-3-50-1 | |
| Bare Drum | 12000 lb (5454 Kp) |
| Mean Drum | 9000 lb (4090 Kp) |
| Full Drum | 7000 lb (3182 Kp) |
| Model H10-3-50-2 | |
| Bare Drum | 10000 lb (4545 Kp) |
| Mean Drum | 8500 lb (3856 Kp) |
| Full Drum | 7300 lb (3318 Kp) |

MAXIMUM LINE SPEED (at Max. Oil Volume)

| Model | Forward | Reverse |
|-------------------------|--------------------|---------------------|
| Model H10-3-50-1 | | |
| Bare Drum | 100 fpm (31 m/min) | 433 fpm (132 m/min) |
| Mean Drum | 140 fpm (43 m/min) | 606 fpm (185 m/min) |
| Full Drum | 175 fpm (53 m/min) | 752 fpm (229 m/min) |
| Model H10-3-50-2 | | |
| Bare Drum | 120 fpm (37 m/min) | 520 fpm (159 m/min) |
| Mean Drum | 145 fpm (44 m/min) | 627 fpm (191 m/min) |
| Full Drum | 170 fpm (52 m/min) | 736 fpm (224 m/min) |

DRUM TORQUE AND RPM

| | |
|-------------------------|----------------------------------|
| Model H10-3-50-1 | 48000 lb/in (553 Kp/m) at 48 RPM |
| Model H10-3-50-2 | 50000 lb/in (576 Kp/m) at 48 RPM |

MAXIMUM OPERATING PRESSURE

| | |
|-------------------------|------------------------------------|
| Model H10-3-50-1 | 2200 PSI (155 Kp/cm ²) |
| Model H10-3-50-2 | 2200 PSI (155 Kp/cm ²) |

MAXIMUM OPERATING VOLUME

| | |
|-------------------------|--------------------|
| Model H10-3-50-1 | 50 GPM (189 l/min) |
| Model H10-3-50-2 | 50 GPM (189 l/min) |

Page 2

Pine Hill Equipment, Inc.
sales@pinehillequipment.com
508-636-5971

INSTALLATION DIMENSIONS

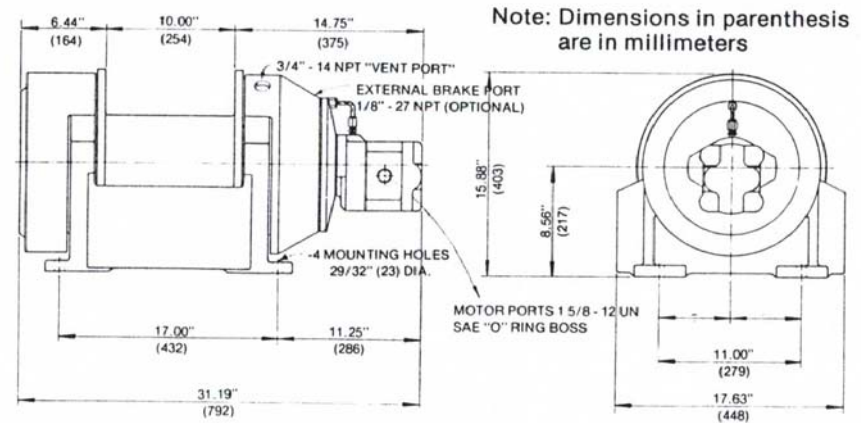

HYDRAULIC PORTS

PORT SIZES:

MOTOR PORT 'B'
MOTOR PORT 'A' > 1 5/8" - 12 UN, SAE 'O' RING
VENT PORT 'C' = 3/4" NPT

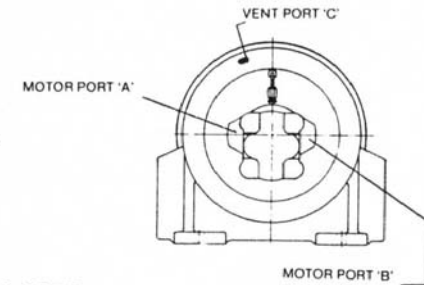

RECOMMENDED HYDRAULIC CIRCUIT

